



SANYO Semiconductors

DATA SHEET

An ON Semiconductor Company

LV8548M

Bi-CMOS integrated circuit

12V Low Saturation Voltage Drive

Forward/Reverse Motor Driver

Overview

The LV8548M is a 2-channel low saturation voltage forward/reverse motor driver IC. It is optimal for motor drive in 12V system products and can drive either two DC motors, one DC motor using parallel connection, or a 2-phase bipolar stepping motor with 1-2 phase excitation mode drive.

Functions

- DMOS output transistor adoption (Upper and lower total $R_{ON}=1\Omega$ typ)
- For one power supply (The control system power supply is unnecessary.)
- Our motor driver IC, LB1948M, and compatible pin
- It is possible to connect it in parallel (parallel, connected operation of drive ch).
- The compact package (MFP-10S) is adopted.
- $V_{CC\ max}=20v$, $I_O\ max=1A$
- Current consumption 0 when standing by
- Built-in brake function

Specifications

Maximum Ratings at $T_a = 25^\circ C$

Parameter	Symbol	Conditions	Ratings	Unit
Maximum power supply voltage	$V_{CC\ max}$		-0.3 to +20	V
Output impression voltage	VOUT		-0.3 to +20	V
Input impression voltage	V_{IN}		-0.3 to +6	V
GND pin outflow current	IGND	For ch	1.0	A
Allowable Power dissipation	$P_d\ max$	*	1.05	W
Operating temperature	Topr		-30 to +85	$^\circ C$
Storage temperature	Tstg		-40 to +150	$^\circ C$

*: When mounted on the specified printed circuit board (57.0mm x57.0mm x 1.6mm), glass epoxy, both sides

Recommended Operating Range at $T_a = 25^\circ C$

Parameter	Symbol	Conditions	Ratings	Unit
Power supply voltage	V_{CC}		4.0 to 16	V
Input "H" level voltage	V_{INH}		+1.8 to +5.5	V
Input "L" level voltage	V_{INL}		-0.3 to +0.7	V

■ Any and all SANYO Semiconductor Co.,Ltd. products described or contained herein are, with regard to "standard application", intended for the use as general electronics equipment (home appliances, AV equipment, communication device, office equipment, industrial equipment etc.). The products mentioned herein shall not be intended for use for any "special application" (medical equipment whose purpose is to sustain life, aerospace instrument, nuclear control device, burning appliances, transportation machine, traffic signal system, safety equipment etc.) that shall require extremely high level of reliability and can directly threaten human lives in case of failure or malfunction of the product or may cause harm to human bodies, nor shall they grant any guarantee thereof. If you should intend to use our products for applications outside the standard applications of our customer who is considering such use and/or outside the scope of our intended standard applications, please consult with us prior to the intended use. If there is no consultation or inquiry before the intended use, our customer shall be solely responsible for the use.

■ Specifications of any and all SANYO Semiconductor Co.,Ltd. products described or contained herein stipulate the performance, characteristics, and functions of the described products in the independent state, and are not guarantees of the performance, characteristics, and functions of the described products as mounted in the customer's products or equipment. To verify symptoms and states that cannot be evaluated in an independent device, the customer should always evaluate and test devices mounted in the customer's products or equipment.

SANYO Semiconductor Co., Ltd.

<http://semicon.sanyo.com/en/network>

LV8548M

Electrical Characteristics at $T_a = 25^\circ\text{C}$, $V_{CC} = 12\text{V}$

Parameter	Symbol	Conditions	Ratings			Unit
			min	typ	max	
Power supply voltage	I_{CC0}	Standby mode $IN1=IN2=IN3=IN4="LOW"$			1	μA
	I_{CC1}	It is "High" from $IN1$ as for either of $IN4$. Load opening		1.7	2.3	mA
Input current	I_{IN}	$V_{IN}=5\text{V}$	35	50	65	μA
Thermal shutdown operating temperature	T_{tsd}	Design certification	150	180	210	$^\circ\text{C}$
Width of temperature hysteresis	ΔT_{tsd}	Design certification		40		$^\circ\text{C}$
Low voltage protection function operation voltage	$V_{thV_{CC}}$		3.3	3.5	3.65	V
Release voltage	V_{thret}		3.55	3.8	3.95	V
Output ON resistance (Upper and lower total)	R_{ON}	$I_{OUT}=1.0\text{A}$	0.7	1	1.25	Ω
Output leak current	I_{Oleak}	$V_O=16\text{V}$			10	μA
Diode forward voltage	V_D	$I_D=1.0\text{A}$		1.0	1.2	V

Package Dimensions

unit : mm (typ)

3086B

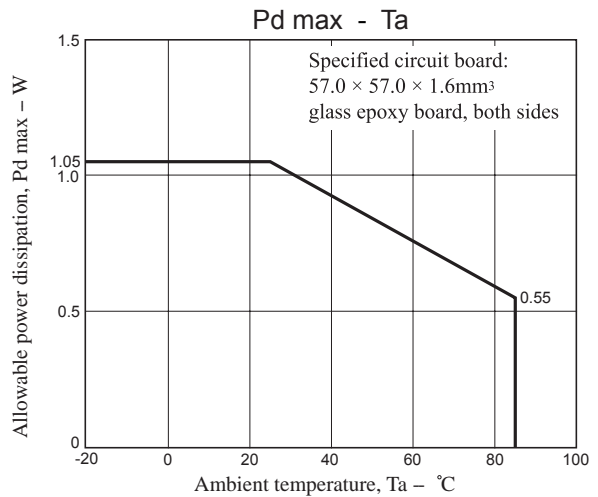
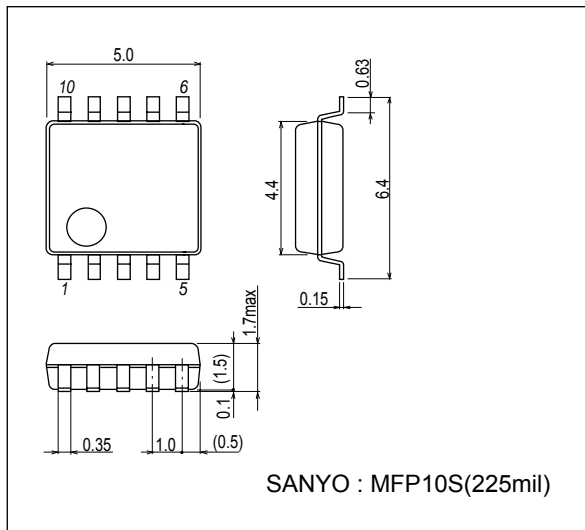

Pin Assignment

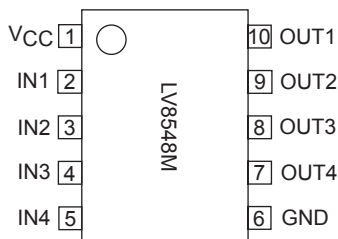

LV8548M

Block Diagram

1. At two DC motor drive

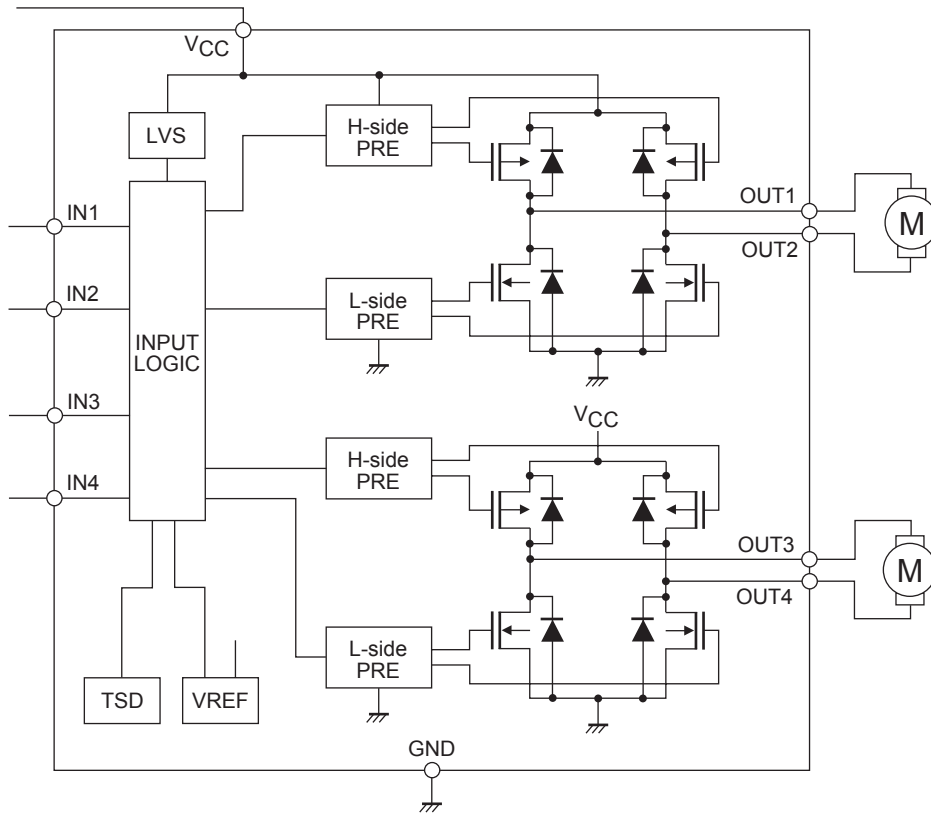

2. At one stepping motor drive

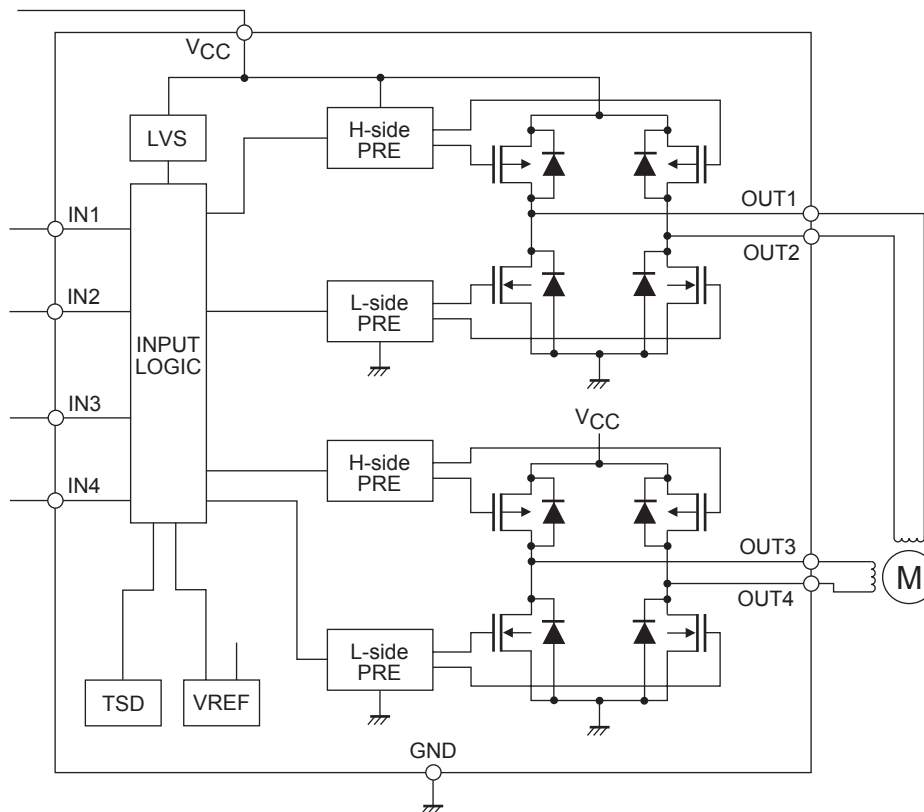

LV8548M

Pin function

Pin No.	Pin name	Pin function	Equivalent Circuit
1	V _{CC}	Power-supply voltage pin. V _{CC} voltage is impressed. The permissible operation voltage is from 4.0 to 16.0(V). The capacitor is connected for stabilization for GND pin (6pin).	
2	IN1	Motor drive control input pin. Driving control input pin of OUT1 (10pin) and OUT2 (9pin). It combines with IN2 pin (3pin) and it fights desperately. The digital input it, range of the "L" level input is 0 to 0.7(V), range of the "H" level input is from 1.8 to 5.5(V). PWM can be input. Pull-down resistance 100(kΩ) is built into in the pin. It becomes a standby mode because all IN1, IN2, IN3, and IN4 pins are made "L", and the circuit current can be adjusted to 0.	
3	IN2	Motor drive control input pin. Driving control input pin of OUT1 (10pin) and OUT2 (9pin). It combines with IN1 pin (2pin) and it uses it. PWM can be input. With built-in pull-down resistance.	
4	IN3	Motor drive control input pin. Driving control input pin of OUT3 (8pin) and OUT4 (7pin). It combines with IN4 pin (5pin) and it uses it. PWM can be input. With built-in pull-down resistance.	
5	IN4	Motor drive control input pin. Driving control input pin of OUT3 (8pin) and OUT4 (7pin). It combines with IN3 pin (4pin) and it uses it. PWM can be input. With built-in pull-down resistance.	
6	GND	Ground pin.	
7	OUT4	Driving output pin. The motor coil is connected between terminal OUT3 (8pin).	
8	OUT3	Driving output pin. The motor coil is connected between terminal OUT4 (7pin).	
9	OUT2	Driving output pin. The motor coil is connected between terminal OUT1 (10pin).	
10	OUT1	Driving output pin. The motor coil is connected between terminal OUT2 (9pin).	

Operation explanation

1. DCM output control logic

Input				Output				Remarks
IN1	IN2	IN3	IN4	OUT1	OUT2	OUT3	OUT4	
L	L	L	L	OFF	OFF	OFF	OFF	Stand-by
L	L			OFF	OFF			Stand-by
H	L			H	L			Forward
L	H			L	H			Reverse
H	H			L	L			Brake
		L	L			OFF	OFF	Stand-by
		H	L			H	L	Forward
		L	H			L	H	Reverse
		H	H			L	L	Brake

LV8548M

2. About the switch time from the stand-by state to the state of operation

When IN1, IN2, IN3, IN4 are "L", this IC has completely stopped operating. After the time of reset of about 4μs of an internal setting, it shifts to a prescribed output status corresponding to the state of the input when the signal enters the input terminal.

Reset of about 4μs doesn't hang even if the motor is driven from the stand-by state when either CH drives and the output becomes an output status corresponding to the state of the input. As for full power TR between the reset time, turning off is maintained.

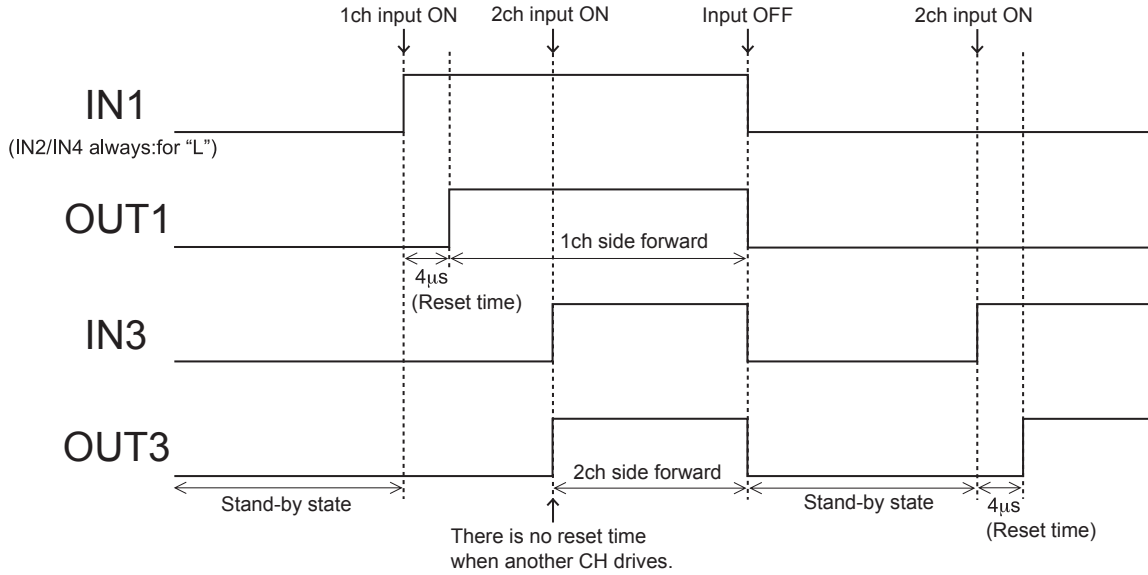

3. Example of current wave type in each excitation mode when stepping motor parallel input is controlled.

• 2 phase excitation

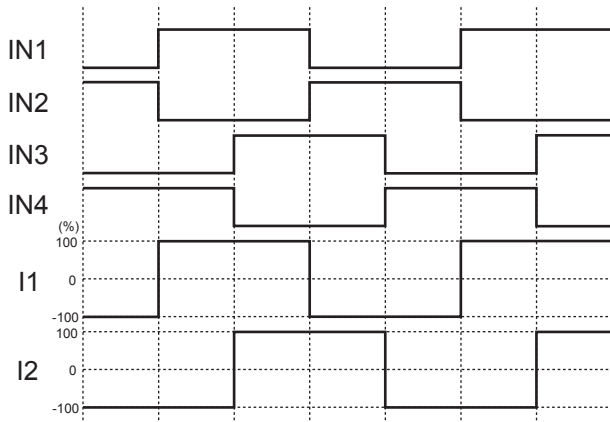

• 1-2 phase excitation

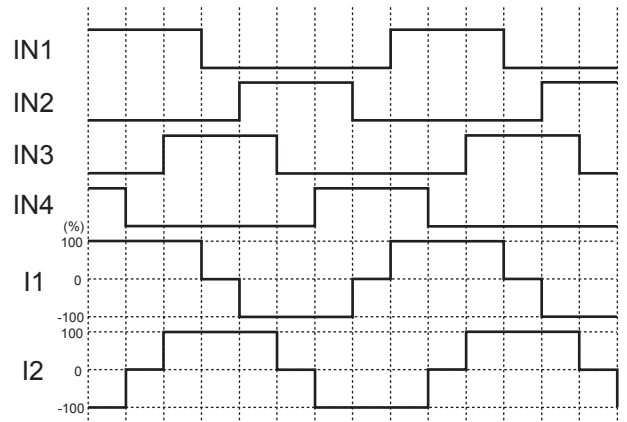

Application Circuit Example

1. Example of applied circuit when two DC motor driving

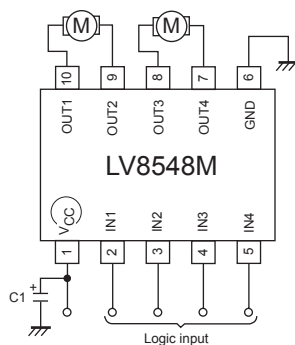

2. Example of applied circuit when one stepping motor driving

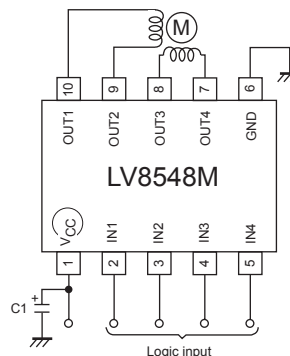

LV8548M

3. Example of applied circuit when connecting it in parallel

The use likened to H bridge 1ch is shown possible in the figure below by connecting IN1 with IN3, IN2 with IN4, OUT1 with OUT3, OUT2, and OUT4. ($I_O \text{ max}=2.0\text{A}$, Upper and lower total $R_{ON}=0.5\Omega$)

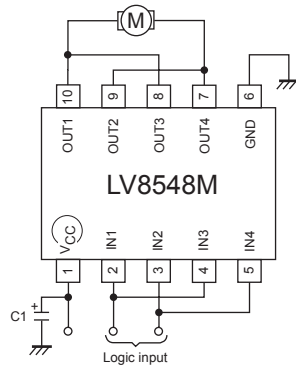

* Bypass capacitor (C1) connected between V_{CC} -GND of all examples of applied circuit recommends the electric field capacitor of $0.1\mu\text{A}$ to $10\mu\text{A}$.

Confirm there is no problem in operation in the state of the motor load including the temperature property about the value of the capacitor.

Mount the position where the capacitor is mounted on nearest IC.

- SANYO Semiconductor Co.,Ltd. assumes no responsibility for equipment failures that result from using products at values that exceed, even momentarily, rated values (such as maximum ratings, operating condition ranges, or other parameters) listed in products specifications of any and all SANYO Semiconductor Co.,Ltd. products described or contained herein.
- SANYO Semiconductor Co.,Ltd. strives to supply high-quality high-reliability products, however, any and all semiconductor products fail or malfunction with some probability. It is possible that these probabilistic failures or malfunction could give rise to accidents or events that could endanger human lives, trouble that could give rise to smoke or fire, or accidents that could cause damage to other property. When designing equipment, adopt safety measures so that these kinds of accidents or events cannot occur. Such measures include but are not limited to protective circuits and error prevention circuits for safe design, redundant design, and structural design.
- In the event that any or all SANYO Semiconductor Co.,Ltd. products described or contained herein are controlled under any of applicable local export control laws and regulations, such products may require the export license from the authorities concerned in accordance with the above law.
- No part of this publication may be reproduced or transmitted in any form or by any means, electronic or mechanical, including photocopying and recording, or any information storage or retrieval system, or otherwise, without the prior written consent of SANYO Semiconductor Co.,Ltd.
- Any and all information described or contained herein are subject to change without notice due to product/technology improvement, etc. When designing equipment, refer to the "Delivery Specification" for the SANYO Semiconductor Co.,Ltd. product that you intend to use.
- Information (including circuit diagrams and circuit parameters) herein is for example only; it is not guaranteed for volume production.
- Upon using the technical information or products described herein, neither warranty nor license shall be granted with regard to intellectual property rights or any other rights of SANYO Semiconductor Co.,Ltd. or any third party. SANYO Semiconductor Co.,Ltd. shall not be liable for any claim or suits with regard to a third party's intellectual property rights which has resulted from the use of the technical information and products mentioned above.

This catalog provides information as of July, 2010. Specifications and information herein are subject to change without notice.